



FCRC-TR 97- 05

Review of Fire-Safety in Shopping Centres: The Key Issues

FCRC Project 6
Fire for

Fire Code
February 1997

Important Notice

This Report has been prepared for work commissioned by Fire Code Reform Centre Limited and has been released for information only.

The statements and conclusions of the Report are those of the author(s) and do not necessarily reflect the views of Fire Code Reform Centre Limited, its Board of Directors or Members.

Neither the authors, Fire Code Reform Centre Limited, nor the organisations and individuals that have contributed, financially or otherwise, to production of this document warrant or make any representation whatsoever regarding its use.

Background

The Fire Code Reform Research Program is funded by voluntary contributions from regulatory authorities, research organisations and industry participants.

Project 6 of the Program involved specific studies into different aspects of fire-safety in low-rise, sprinklered shopping centres. When these separate studies had advanced sufficiently a review was undertaken by Associate Professor Paula Beever of Victoria University of Technology to identify the Key Issues involved.

Dr Ian Bennetts of BHP Research, Melbourne Laboratories 245 Wellington Road, Mulgrave, Victoria 3170 incorporated the comments provided in Professor Beever's Report when undertaking the concluding stages and formulating the final recommendations of the project.

Acknowledgements

Mr Max Croxford, Commissioner of the Building Control Commission (BCC), Victoria was primarily responsible for the initiation of FCRC's Project 6 relating to "Fire Safety Systems in Low-Rise, Sprinklered Shopping Centres". BCC Victoria additionally provided significant financial support to the execution of this work. BHP Steel Division and BHP Research **were** further contributors of substantial funds to Project 6. Generous contributions were also received from other donors.

The Board and management of Fire Code Reform Centre Limited acknowledge with sincere thanks receipt of all these financial contributions. The company also acknowledges the kind permission of BHP Research to the re-production and publishing of this document.

Comments

Comments on _____ or _____
should be _____ Reform Centre Ltd, Suite 1201, 12th Floor, 66 King St.,
2000, Australia. Tel. (2) _____ Fax. (2) 9262 4255.

FIRE CODE REFORM CENTRE
PROJECT 6

BHPR/SM/R/G/060

**REVIEW OF FIRE SAFETY IN SHOPPING
CENTRES: THE KEY ISSUES**

by

VUT—P F Beaver; BCC—A C Lee;
BHPR-I D Bennetts, K W Poh, S L Poon

Refereed by:

February 1997

Circulation: Unrestricted

The Broken Hill Proprietary Company Limited
A.C.N. 004 028 077

EXECUTIVE SUMMARY

A series of studies has been undertaken with the aim of establishing a rational basis for the review of fire safety measures in low rise sprinklered shopping centres. The studies have addressed relevant matters from several different angles, including analysis of statistics, reviews of regulatory requirements, surveys of shopping centre characteristics, and interviews with shopping centre management and staff.

This report sets out to describe the studies and their outcomes in a concise manner, detailed descriptions of the work being given elsewhere. The reviews have raised a number of questions about the effectiveness and cost of certain fire safety systems in shopping centres, both in terms of construction costs and in running maintenance, whilst at the same time affirming that these are places which generally present very low risk to life from fire. The results of the work have indicated areas where alterations to the BCA requirements would be beneficial both in terms of the cost-effectiveness of the results and the functionality of the buildings without decreasing their fire safety.

The report then goes on to describe how the amendments proposed for inclusion within the BCA may be analysed to assess their effects. It is proposed that fire risk assessment modelling be undertaken to demonstrate that the effects of the changes does not have a significant bearing on the expected risk to life. The modelling work is being supported by a comprehensive experimental program, specific surveys and a set of position papers on shopping centre issues

CONTENTS

	<i>Page No.</i>
1. INTRODUCTION	1
2. ANALYSIS OF FIRE INCIDENTS IN RETAIL PREMISES	2
3: EVIDENCE FROM FIRE STATISTICS	3
3.1 Sources of Data	3
3.2 Fatality Rate	3
3.3 Fire Spread	3
3.4 Time of Day	4
3.5 Sprinkler Performance	4
3.6 Detector Performance	4
3.7 Fire Brigade Arrival	5
3.8 Conclusions	5
4. BCA REQUIREMENTS	5
4.1 General Remarks	6
4.2 Fire Resistance and Compartmentation	6
4.3 Evacuation	7
4.4 Firefighting Provisions	8
4.5 Smoke Control	8
4.6 Atrium Requirements	10
4.6.1 Background	10
4.6.2 Boundary Wall Construction	10
4.6.4 Roof Separation	10
4.6.5 Smoke Hazard Management	13
4.6.6 Other Aspects	13
4.7 Sprinklers	13
4.8 Summary	13
5. ISSUES EMERGING FROM SHOPPING CENTRE SURVEY	14
5.1 Scope	14
5.2 Detailed Shopping Centre Study	14
5.2.1 Information Gathering	14
5.2.2 Specialty Shops-Characteristics	14
5.2.3 Specialty Shops-Measured Fire Loads	15
5.2.4 Major Stores	15
5.2.5 Populations	15
5.3 General Observations on Shopping Centres	18
5.3.1 Characteristics of the Centres	18
5.3.2 Fire Incidents	18
5.3.3 Construction and Refurbishment	18
5.3.4 Maintenance Issues	19

5.3.5	Sprinkler Systems	19
5.3.6	Evacuation	21
5.3.7	Combustibles within the Mall	21
5.4	Concluding Remarks	21
6.	OPPORTUNITIES FOR CHANGE	22
6.1	Integration of Fire safety Systems	22
6.2	Use of Results Obtained to Date	22
6.3	Summary of Future Activities	23
7.	SUPPORTING EXPERIMENTAL PROGRAM	24
7.2	Purpose	24
7.3	Setup	24
7.4	Measurements	24
8.	PROPOSED METHODOLOGY FOR MODELLING OF FIRE RISK	26
8.1	Philosophy	26
8.2	Parameters for Study	26
8.3	Fire safety Model	27
8.3.1	Typical Layouts	27
8.3.2	Evacuation Modelling	27
8.3.3	Fire Development Modelling	27
8.3.4	Fire Brigade Intervention	29
9.	CONCLUSIONS	30
10.	SIGNATURE PAGE	31
11.	REFERENCES	32
APPENDIX A	QUESTIONS EMERGING FROM THE STUDIES TO BE ADDRESSED BY PROJECT 6	33

1. INTRODUCTION

The construction of large shopping centres is an area of commercial development which is being pursued very actively in Australia at present. There is a belief that the current regulatory requirements for fire protection of these buildings may be unnecessarily onerous, imposing financial burdens on developers and owners which may not relate to the risk to life from fire in these buildings. The remit of Fire Code Reform Centre Project 6 is to review the requirements in the Building Code of Australia (BCA) which apply to low-rise sprinklered shopping centres, and to propose a more rationally based set of requirements which will improve the cost effectiveness of these buildings both in terms of construction costs and maintenance in operation without decreasing their fire safety.

As part of this research Project a detailed study of the BCA requirements as they pertain to sprinklered shopping centres has been completed [1]. Case study and statistical data has been reviewed [2, 3-5] with a view to identifying common features in serious fires and factors leading to fatalities. In addition, an in-depth study of modern shopping centres in Australia has been undertaken [6]. That study reviewed all major aspects of shopping centres as they relate to fire safety issues-construction details, quantities and distribution of combustibles, population characteristics, emergency exit layout, sprinkler systems, smoke control systems, detection and alarm systems. The study looked not only at aspects of hardware but sought to come to terms with significant maintenance and management issues. It also set out to understand the concerns of designers and shopping centre management with respect to the cost and effectiveness of current fire safety requirements for these buildings.

The purpose of this report is to present clearly the key issues identified by the above studies, and to propose a methodology for deriving alternative provisions. This is not to suggest that there is no valid basis for many of the BCA fire-safety requirements, but rather that a review of their effectiveness is required in relation to sprinklered low-rise shopping centres. It may be that there is a sufficient evidence to show that modification of some of these requirements is reasonable.

2. ANALYSIS OF FIRE INCIDENTS IN RETAIL PREMISES

A set of case studies of serious fires in retail premises has been analysed in detail and reported elsewhere [2]. The data concerning these fires was taken from published information in journals and reports from all over the world. They represent a set of accounts of fires which might be considered to be of special interest in some way where the loss was particularly large or where some noteworthy fire safety issues were demonstrated. The level and type of detail obtained for each fire varies, depending on the length of the article, and the viewpoint of the writer concerning what was seen to be important- This sample of case studies cannot therefore be considered to be statistically unbiased. Nevertheless, the study of serious incidents can reveal trends which merit further investigation.

As part of the same report, detailed information on fatal fires is presented, obtained in relation to retail premises in the USA over a 10 year period from 1983 to 1993 (excepting 1986 which was unavailable). This data was drawn from a pool of almost 78,000. fires in which there were a total of 86 deaths. The conclusions from this part of the study can be regarded as statistically valid, since all cases attended by the fire brigade in the data base are included. The incidence of fire deaths in retail premises in Australia is very small', and it is assumed here that the broad conclusions drawn from an analysis of the much larger US database would be valid for Australian shopping centres. This assumption is borne out by a recent analysis of the statistics for fires in retail premises for New South Wales, to be described in the following section of this report

The analysis of the case studies revealed a number of features. Firstly, fires tend to become large if they start in concealed spaces or when the building is unoccupied. Sprinklers generally serve to keep a fire small, but partial sprinkler protection of a building may be of limited effectiveness, if the fire occurs in a non-sprinklered part. Fire brigade intervention is particularly effective, if the fire has not been allowed to become large.

The analysis of fatal fires from the US statistics shows that over two thirds of fatalities involve individuals who are asleep or otherwise impaired at the time of the fire, or were intimately involved with the ignition. A large proportion of deaths (somewhere between 43% and 62%) occur in fires which involve flammable liquids, especially petrol. Since incidence of people being asleep or involved with flammable liquids in the shopping centres under discussion in this report would be very low, it was concluded that the risk of death in fire in a shopping centre, is much lower even than that indicated by the US statistics. Where the building was sprinklered, multiple fire deaths were recorded in only a single instance. In that case, despite the fact that the sprinklers confined the fire to the object of origin, it appears that the victims died due to burning petrol. Other details of this case are being followed up.

¹ For fires in retail premises in New South Wales over the period 1986-1992, there were 2 fatalities.

3. EVIDENCE FROM FIRE STATISTICS

3.1 SOURCES OF DATA

A study [3] has been carried out to analyse the statistical data on USA retail fires attended by the fire brigade contained in the NFIRS [7] database for the 10 years 1983 to 1993 excluding 1986 for which data was unavailable. All fires were classified as structure fires, that is building as opposed to vehicle, ship or outdoor fires. The conclusions of the report are very pertinent to the present study. For comparison, a further study was carried out on data available from the NSW Fire Brigades for New South Wales for the years 1986 to 1992 [4]. An analysis of Australian fire statistics for commercial buildings has also been undertaken [5].

3.2 FATALITY RATE

Firstly it is clear both from the US data and from the rather more limited data from Australia that retail premises do not present a significant risk to life from fire. The US data shows that the average fatality rate for civilians (as opposed to firefighters) is 1.12 deaths per 1000 fires, which may be compared with the figure for residential apartments, from the same source, of 7.4 civilian fatalities per 1000 fires. In New South Wales the comparable figure for retail premises is 0.79 deaths per 1000 fires, but since this is based on only two fatal fire incidents, the figure must be used with caution. There is a general trend, as might be expected, for the numbers of civilian deaths and injuries to increase with size of the fire. In fact it is shown in the analysis given in [3] that if by some means all fires could be confined to the object first ignited, the civilian fatality rate would fall by a factor of nine.

As noted in [2] a high proportion of fatalities are associated with those who are asleep or intimately involved with ignition and flammable liquids. Since these factors are unlikely to be present in the shopping centres under consideration it seems likely that the relevant fatality rate is much lower than the average US figure of 1.12 civilian deaths per 1000 fires.

3.3 FIRE SPREAD

The US statistics record the extent of flame damage in the following categories:

- confined to object of origin
- confined to part of room or area of fire origin
- confined to room of fire origin
- confined to fire-rated compartment of fire origin
- confined to floor of fire origin
- confined to structure of origin
- extended beyond structure of fire origin

Where flame damage was recorded, the largest category of fires, 47%, are those confined to the object of fire origin: 80% of fires were confined to the room of fire origin. From the NSW data is the comparable figure for the latter is 78%. Very few fires which spread beyond the room of fire origin are confined to the

compartment of fire origin. Only 3% of fires where flame damage is recorded spread beyond the structure of fire origin.

3.4 TIME OF DAY

More fires occur in the day than at night. However the statistics show that daytime fires have a greater chance of being confined to the object of origin, whilst night time fires have a greater chance of becoming large. In parallel the rate of civilian deaths in fire is greater at night, but the rate of injuries is greater in the day (presumably because there are more fires in the day).

3.5 SPRINKLER PERFORMANCE

Sprinkler performance in the US statistics is recorded in one of the following categories:

- equipment operated
- equipment should have operated but did not
- equipment present but fire too small to require operation
- no equipment present in room or space of fire origin

The number of fires recorded where there were no sprinklers (or unknown) is substantially greater than when sprinklers were present. Where there were sprinklers in 69% of cases they did not operate, but the overwhelming majority (93.5%) of these were recorded as being because the fire was too small. The proportion of fires where the sprinklers were present and should have operated (but did not) is therefore quite small, suggesting high reliability.

The statistics show that sprinklers are very effective in containing the fire, as would be expected. With sprinklers present, whether they operated or not, 60% of fires were confined to the object of origin whereas without sprinklers, the figure is 44%. With sprinklers present, 94% of fires do not spread beyond the room of fire origin, whilst without sprinklers the figure is 78%. Another way of expressing these figures is to note that with sprinklers not present, 22% of fires cause damage beyond the room of fire origin, but with sprinklers present this reduced to 6%-a fourfold reduction.

The overall rate of civilian fatalities was 0.5 per 1000 fires with sprinklers present, compared to the average for all fires of 1.12 per 1000 fires. Average property damage was reduced by one third by the presence of sprinklers. It is likely that these figures substantially underestimate the real value of sprinklers due to the fact that sprinklers are required in most larger buildings and the potential damage and loss of life associated with a non-sprinklered fire in such buildings would be very substantial [8]. If the data for *shopping complexes* only are considered, as opposed to service stations and garages, then the fatality rate drops to zero for sprinklered buildings and is greatly reduced for non-sprinklered buildings.

3.6 DETECTOR PERFORMANCE

The statistics show that in less than 20% of fires where the presence or absence of detectors was recorded were there detectors present. In about 50% of

these cases the detectors did not operate, though over half of these were attributed to the fact that the fire was too small. The rate of civilian fire fatalities with detectors present was found to be 0.41 per 1000 fires which may be compared to the average civilian fatality rate of 1.12 per 1000 fires.

3.7 **FIRE BRIGADE ARRIVAL**

For fires for which times have been recorded, the fire brigade arrived in 90% of cases within 9 minutes of receiving an alarm. In 50% of cases attendance was within 3 minutes. The fire brigade had a significant effect on the extent of flame damage if they arrived early enough. In the 0 to 4 minute category of arrival times, 49% of fires were confined to the object of fire origin, compared with 35% in the 15 to 19 minute interval.

3.8 **CONCLUSIONS**

The statistical study has demonstrated that high levels of fire safety are achieved in shopping centres, compared for example to residential occupancies. It has also set the value of fire safety systems in context, showing that the presence of sprinklers or detectors reduces the civilian fire fatality rate by more than a half compared to the rate for all fires in retail premises.

The clear message is that the risk to life can be reduced significantly if the fire is kept small. Sprinklers, detectors and fire fighters all have an influence on containing fire spread. Large fires, with increased risk to life, tend to occur at night. Fire fatalities occur predominantly in the very young, the elderly and those intimately involved with the fire, and are more likely to involve sleeping individuals. Trends observed in the US database tended to be reflected in the NSW and Australian data.

A much more complete analysis of the statistical data and its implications for shopping centre design is given elsewhere [3-5] and will be reviewed as part of the overall fire-safety analysis being undertaken for these buildings.

4. BCA REQUIREMENTS

4.1 GENERAL REMARKS

A previous report [1] has analysed in detail the requirements for shopping centres as called up in the 1990 edition of the BCA. The 1996 version of the BCA recasts the code into performance terms and the detailed requirements then become deemed-to-satisfy provisions. Some of the provisions have changed from those in the BCA '90 but little has changed that directly affects this project; nevertheless, any changes will be considered where appropriate. One difficulty with an attempt to review the provisions has always been that the BCA requirements have arisen over a long period of time and from amalgamations of earlier documents, and the reasons behind individual requirements are sometimes far from clear. The performance-based BCA 96 goes some way towards solving this problem, but even still the rationale behind particular requirements is often not stated explicitly.

In attempting to determine how normal provisions may be modified in the light of alternative solutions, the BCA frequently makes use of the term 'concessions'. As these alternative requirements are permitted within the code, it follows that they must be considered to correspond to an equivalent level of safety in certain situations-namely the situations specified in the 'concession'. The use of the word 'concession' unfortunately implies a lower level of safety, which is not the case. The use of the term has therefore been avoided in the Project 6 documentation. In more general discussion of alternative solutions use is also made of the term 'trade-off' to describe the inclusion of one fire safety system as compensation for the removal of another such as lowering of fire resistance in cases where a building is sprinklered. Once again, this term suggests an unquantified process, and its use is avoided here in favour of an integrated analysis to establish more effective combinations of fire safety systems.

Many of the provisions in the BCA appear to apply to shopping centres by default, having arisen from more general building requirements. However, shopping centres have very particular attributes which contribute to fire safety by means of design, construction and use. For example the layout of a typical shopping centre is fairly simple, and the wide malls invariably lead to large exits to outside-this being necessary to provide the "sense of openness" and to allow the efficient movement of people. The occupants are alert and generally mobile, and the shopping centres are subject to a high level of management control. By allowing the regulations for shopping centres to be comparable with more general requirements, it has not been possible in the past to take advantage of this combination of inherent fire safety features. In fact the analysis of BCA provisions suggests that rather the reverse is perceived to be the case: shopping malls and atriums attract very severe requirements in terms of smoke control for which very few if any benefits are conceded.

4.2 FIRE RESISTANCE AND COMPARTMENTATION

The fire resistance level (FRL) required for structural elements within a shopping centre varies with the rise *in storey* of the building. The resulting combinations of FRL requirements are complex, probably unnecessarily so. These have been summarised in detail in a separate report [1].

Table C2.2 in the BCA relates the type of construction required to the floor area (or volume) of the compartment (or building if there is only one compartment). Modern shopping centres, due to the substantial openings at each floor level must be considered as one compartment. These compartmentation requirements are therefore not usually relevant, because shopping centres generally have to satisfy the requirements for large isolated buildings (Clause C2.3) which means that they have full sprinkler systems, access for fire fighting vehicles (Clause C2.4 (b)) and have smoke exhaust or smoke and heat vents. There is no BCA requirement to subcompartment sole occupancy units, a classification which would apply to most shops.

The Type of construction required is very sensitive to the rise in storeys. For example, a building with a rise in storeys of two which incorporates 2 basement levels is Type C construction (least fire resisting) whilst a building with a rise in storeys of four with no basements is Type A construction². Type B construction is required if the building has a rise in storeys of three. In Type B Construction, according to Table 4 in Specification C1.1, fire walls, common walls, internal columns and external walls are required to have a fire-resistance level-but there is no such requirement for the floors or roof. Of course, because of the 'support of another part' requirements noted above, Clause C2.2 of the BCA will require the floors to have an FRL unless it can be shown that the columns can achieve the required fire resistance without the presence of lateral support from the floors. On a related matter, it should be noted that internal columns and loadbearing internal walls (other than firewalls) within the top storey of a building of Type A construction (see BCA Spec C1.1, Clause 3.7) require no FRL provided the rise in storeys is not greater than 3 (and 60 minutes if the rise in storeys is greater than 3).

Because the fire resistance requirements vary with *rise in storey*, it is beneficial from a code standpoint in some cases to separate a shopping centre with areas of different heights by fire walls. It is not easy to identify any fire safety benefit which flows from such separation. Access through a fire wall must be by means of a fire door. Fire doors in daily use are found to be heavy and inconvenient, subject to damage and expensive to replace.

Shopping centres frequently incorporate buildings or parts having different classifications (car-park, retail building, cinema). According to BCA Clause C2.8(a), if such buildings of different classifications are adjacent to each other, then either the elements in both buildings must have an FRL which is the highest associated with each classification, or a fire wall must separate the two buildings. Access between the different classes of buildings is required in practice and openings must therefore be provided through the walls, with the associated disadvantages of *fire* doors noted above.

4.3 EVACUATION

The means of escape requirements for shopping centres are largely the same as those for other building types, notwithstanding the relative safety which exists within sprinklered buildings with no sleeping risk. BCA Clause D1.4 gives requirements with respect to the maximum distance to an exit which frequently

² Admittedly the basement levels must have additional exit paths to ground level.

requires the construction of fire-isolated passages for people to evacuate from the mall, and the introduction of fire-isolated staircases from the upper levels which would not be required for normal circulation. These routes may, in some cases, represent wasted space as the same tunnels cannot be used for service access to the shops without the introduction of smoke lobbies or pressurisation. Clause D 1.6 specifies the total width of exits required.

Emergency Warning and Intercommunication Systems (EWIS) are only required by the BCA if the building is greater than 25m, or contains an atrium or a cinema. In view of the large numbers of people which could be in a shopping centre at busy times, the question could be raised as to whether an emergency warning system should be required for all shopping centres having a floor area greater than a limiting size. Indeed such systems are common in larger centres.

4.4 FIREFIGHTING PROVISIONS

The requirements for large isolated buildings in the BCA mean that there has to be access for fire fighting vehicles around the whole perimeter of the building. This requirement may interfere with efficient car park design, and its value has to be questioned.

4.5 SMOKE CONTROL

The deemed-to-satisfy provisions of the BCA result in quite onerous requirements for smoke control systems in malls and atria, which are highly expensive, and in many cases require complex control systems for successful operation. It may be that the new performance BCA when it is adopted will give designers the opportunity to design simpler smoke control systems in an integrated manner which takes into account escape time in the context of tenability of the conditions on escape routes. Proposals for how this might be achieved, and comments on the reliability of smoke control systems will be a subject of a future report.

There are many factors associated with the management of the smoke hazard in these buildings. Smoke exhaust or venting systems may form part of a smoke hazard management system. Depending on the floor area of the shopping centre and whether there is a covered walkway or mall, smoke exhaust may be required for the mall and this will be achieved by reservoirs and fans or vents (Figure 4.1 - see Figures 7.4 (a) and 7.5 (a) in [1]). Shops greater than 1000m² and opening into the mall must have a dedicated smoke exhaust system, which again, will

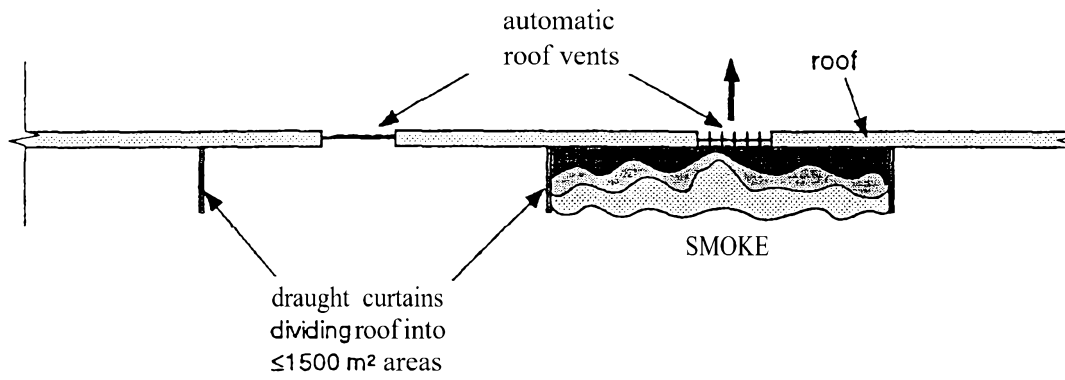

a) draught curtains

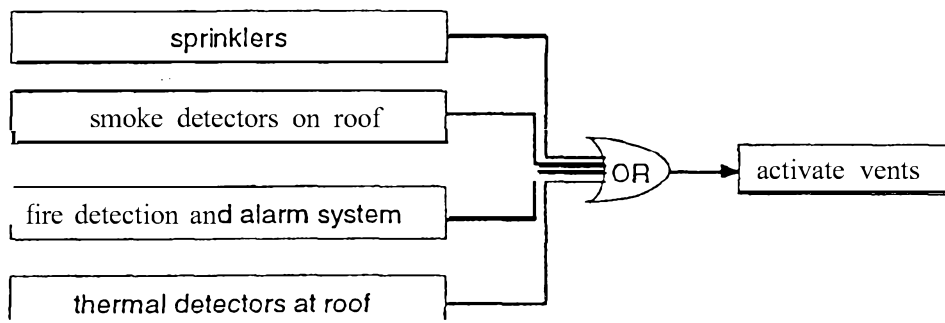

b) means of activation

FIGURE 4.1 SMOKE EXHAUST SYSTEM REQUIRED FOR MALL

require exhaust fans and bulkheads or baffles. If a major store is a multi-storey single compartment then the system must satisfy the requirements shown schematically in Figure 4.2 (see Fig 7.6 in [1]) . Such systems are complicated and it is important to understand the likelihood of correct operation. It is possible that both the mall system and that associated with a multi-storey single compartment may operate at the one time should smoke be detected in both areas. The way in which the two systems interact needs to be studied.

4.6 ATRIUM REQUIREMENTS

4.6.1 BACKGROUND

Many shopping centres have atriums to improve the level of natural light in large deep spaces, to provide visual interest and clearly identifiable access routes between levels. The BCA requirements for atriums are particularly onerous. The atrium provisions only apply to multi-storey sprinklered shopping centres which have a rise in storeys of more than 3.

4.6.2 BOUNDARY WALL CONSTRUCTION

An atrium well typically requires separation from the remainder of the building by bounding wall construction, with a setback of not greater than 3.5 m from the perimeter of the atrium well (see Sections 8.1 and 8.2 of [1]). Boundary wall construction is required by the BCA (Clause G3.3) at all levels, with the exception of 3 consecutive storeys if:

- (i) one of these storeys is at a level at which direct egress to a road or open space is provided; and
- (ii) the sum of the floor areas of those storeys that are contained within the atrium is not more than the maximum area that is permitted in Table C2.2. See Figure 4.3 (Figure 8.1 of [1]).

Condition (i) is normally achieved within shopping centre atria; however, item (ii) requires extensive compartmentation of the floor levels or the construction of bounding walls within 3.5 m of the atrium well. A literal interpretation of item (ii) refers to Table C2.2 and therefore disallows the use of the provisions for large isolated buildings Clause C2.3.

4.6.4 ROOF SEPARATION

As discussed in Section 8.3 of [1], according to Clause G3.6 of the BCA, the roof structure and membrane must have an FRL of 180/60/30, depending on the type of construction, or be protected by a sprinkler system. Clause 5.4.3 of AS 2118 [9] requires roofs to be sprinklered. Clause G3.8 also specifies that sprinkler protection to be provided at the roof of an atrium, though it is likely in many situations that the heads would be too far from potential fire sources to be effective.

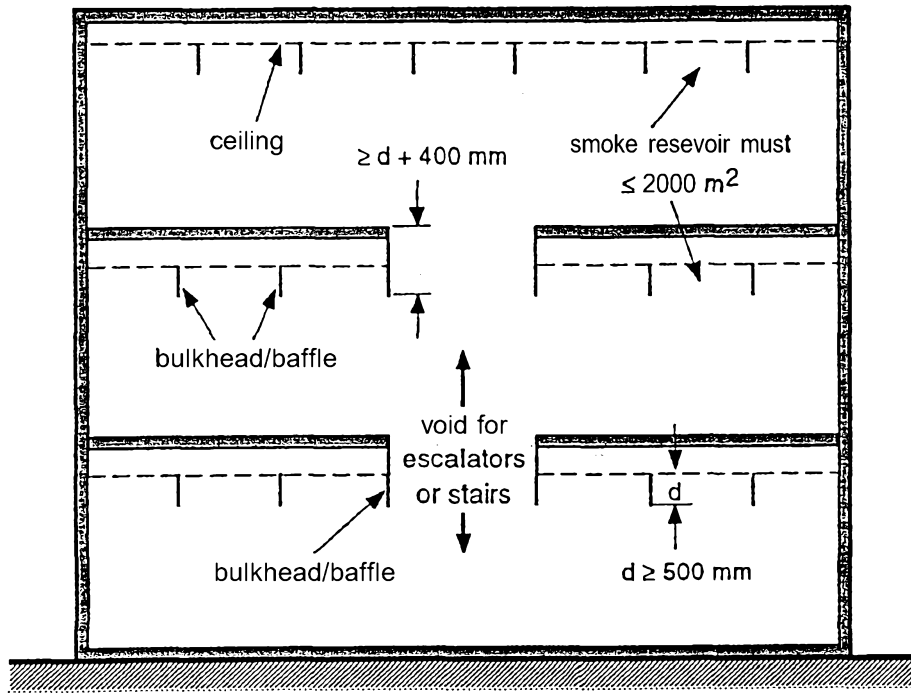

a)

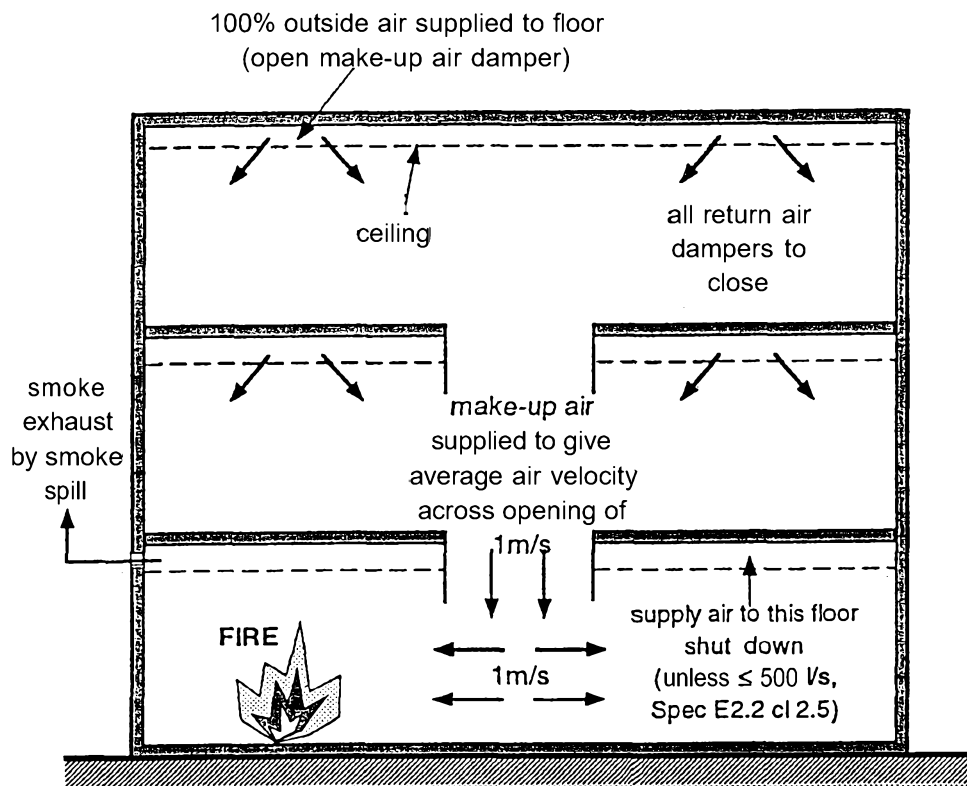

b)

in Fire Mode

FIGURE 4.2 SMOKE EXHAUST SYSTEM FOR MAJOR STORE

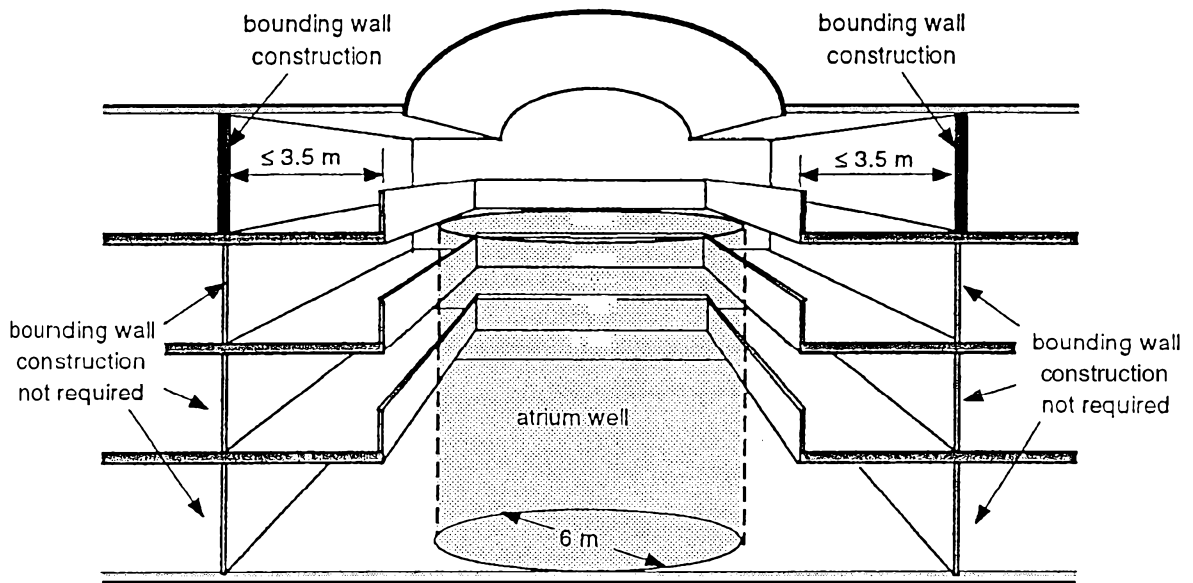

FIGURE 4.3 SEPARATION REQUIREMENTS FOR ATRIUM

4.65 SMOKE HAZARD MANAGEMENT

Specification G3.8, Clause 3.7 does not allow the use of smoke or heat vents in an atrium when a Clause 6 part of the building adjoins the atrium. However Table E2.2 allow the use of either smoke exhaust or smoke and heat vents in malls or walkways when required. The logic of the BCA requirement would appear to be questionable.

Stair Pressurisation is required in fire isolated exits in a building containing an atrium, though it would not be required in other low-rise buildings.

4.6.6 OTHER ASPECTS

Alarm systems required for a building with an atrium include a **break-glass** fire alarm at each door to a fire-isolated stairway, ramp, and passage. If a required path of travel to an exit is within an atrium, a suitable alternative power supply must be provided to operate required safety systems, including sprinkler systems and hydrant pumps, air handling systems, alarms, warning and communication systems, and emergency lighting circuits. If this standby supply is within the building, it must be within an enclosure having an FRL of 120/120/120 (see Section 8.5 of [1]).

4.7 SPRINKLERS

Smoke control systems in shopping centres depend in their underlying assumptions concerning design fire size on the sprinklers operating. However the basis for the design fires used is rather scant, and needs to be reviewed. Sprinkler reliability is clearly a serious issue for shopping centre fire safety, but the management of sprinkler systems (as opposed to their maintenance) is not covered by the BCA. A Grade III water supply only is required if the building has an effective height of less than 25m and many modern shopping centres are less than 25m in height. Clause 5.4.3 of AS 2118 requires roofs to be sprinklered. This rule is currently applied to the mall roofs.

4.8 SUMMARY

The review of the BCA provisions given in [1] provides a useful and succinct summary in one document of all the requirements which apply to shopping centres which are otherwise scattered throughout the BCA. The review has highlighted inconsistencies within some of the requirements themselves, and has given rise to questions as to the value of some others, particularly in relation to atriums. The points raised in the foregoing paragraphs are summarised in Appendix A as a series of questions which need to be addressed in the course of the Project 6 study. The purpose of the analysis to be carried out will be to determine which of the BCA provisions are significant in protecting risk to life from fire in shopping centres and which are not cost effective to include because the benefits conferred are so small.

5. ISSUES EMERGING FROM SHOPPING CENTRE SURVEY

5.1 SCOPE

The survey of Australian Shopping Centres carried out as part of this Project is described in detail elsewhere[6]. A total of 11 Shopping Centres in Victoria and New South Wales were studied, one of which was surveyed in detail. The oldest had been opened in 1960 and the newest in 1990. The older shopping centres had been extended and refurbished a number of times. The aim of this part of the study was to establish how large shopping centres are laid out, occupied, constructed and managed. The study identified the numbers and types of retail premises present, the numbers of people actually using the centres, the general and local fire protection measures installed, and the management training and policies with respect to response to an emergency. This section of the present report summarises these findings and their implications for the review. Many of the problems identified with BCA provisions outlined above have arisen as comments from shopping centre owners and managers obtained as part of the survey.

5.2 DETAILED SHOPPING CENTRE STUDY

5.2.1 INFORMATION GATHERING

The shopping centre selected for detailed study has a rentable sales area of an additional concourse area of 10,000m², constructed on two levels with 187 specialty shops and 5 major stores. Information for the study described here was obtained by a small team of experienced investigators over a period of two months. Every shop in the centre was surveyed with a view to establishing its construction, layout, fire load and the views of staff as to emergency procedures. Both public and reserve areas were included in the study. The measurements made in each shop are summarised in detail in Appendix B of [6].

5.2.2 SPECIALTY SHOPS—CHARACTERISTICS

All shops were categorised according to the type of business conducted there (see Table 5.1). The results are summarised *in* Figure 5.1 (see Figure 3.1 of [6]). It can be seen that the greatest proportion of retail area (over 30%) is given over to clothing shops with each other single use amounting to less than 5% of the total. The area of each shop was measured. Speciality shops have a typical area of 75-100m² (45% of shops) with about 10% being less than 25m², and about 10% being greater than 250m².

Given the development of a significant fire in a shop, ceilings, floor coverings and (at night) security shutters may have an influence on fire growth and development. The survey revealed that 58% of shops had plasterboard ceilings, which would exhibit some fire resistance, and about 23% had mineral fibre tiles which would have less. The remainder were mixed or other construction. Floors were marble or ceramic tile in 26% of cases, and carpet in 25%. The rest were timber, vinyl, mixed or other covering. In 70% of shops the security grill was a closed shutter or a solid door, both of which might have the effect of limiting fire

growth, by restricting the supply of oxygen. In the remainder of cases there was either no grill, or an open grill.

TABLE 5.1 CATEGORIES FOR SPECIALTY SHOPS

Specialty Shops					
accessories	ac	food & beverages	fb	miscellaneous	ms
chemists/cosmetics	ch	food shop	fd	photography	ph
clothing	ci	footwear	ft	sports	sp
coffee lounge	co	gifts	gf	stationery/books	st
electrical/musical	el	hairdressing/beauty	hb	toys/games/bobbies	ty
entertainment	en	homewares/manchester	hm	travel	tr
eyewear	ey	jewehy	jw	variety/discount	va
financial	fn	medical	md		

5.2.3 SPECIALTY LOADS

The average fire load densities expressed in wood equivalent were estimated for all shops. During the survey it was observed that the fire load density in the reserve areas of shops was generally lower than the average value. A notable exception was footwear shops where the fire load density in the reserve areas is much higher than in the public areas. The fire load density values (when measured in wood equivalent) gave a mean of 41 kg/m² but varied widely from virtually nil for jewellers to values approaching 180 kg/m² for stationers. Though much emphasis is placed on fire load density for certain purpose, it is a crude measure of fire risk. One carpet shop in the study gave a very high value of 270 kg/m² for fire load arising from the fact that rugs were piled flat one on top of another—a situation which would not permit rapid fire growth. In other cases a significant proportion of the fire load came from furniture or shelving used to the display goods, rather than from the goods on sale.

5.2.4 MAJOR STORES

Major stores were taken as those in excess of 1000m² in area. A department store and a discount variety store were assessed in detail with respect to fire load.

5.2.5 POPULATIONS

The number of people passing through the entrances to the shopping centre under study is routinely measured by door count devices. Details on a hourly basis for the first two weeks on November 1996 are given in Figure 3.12 of [6]. More general information by week for several years is shown in Figure 3.13 of [6]. A monthly summary is given in Figure 5.2. Management advice is that people spend an average of 2 hours in the Centre, which permits the flow figures to be converted to population values.

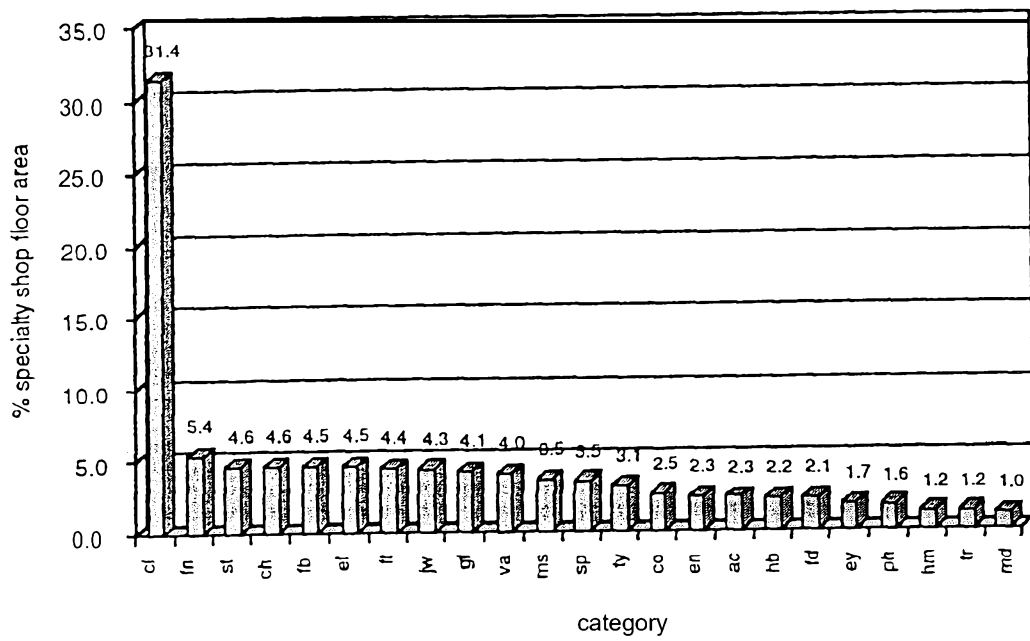
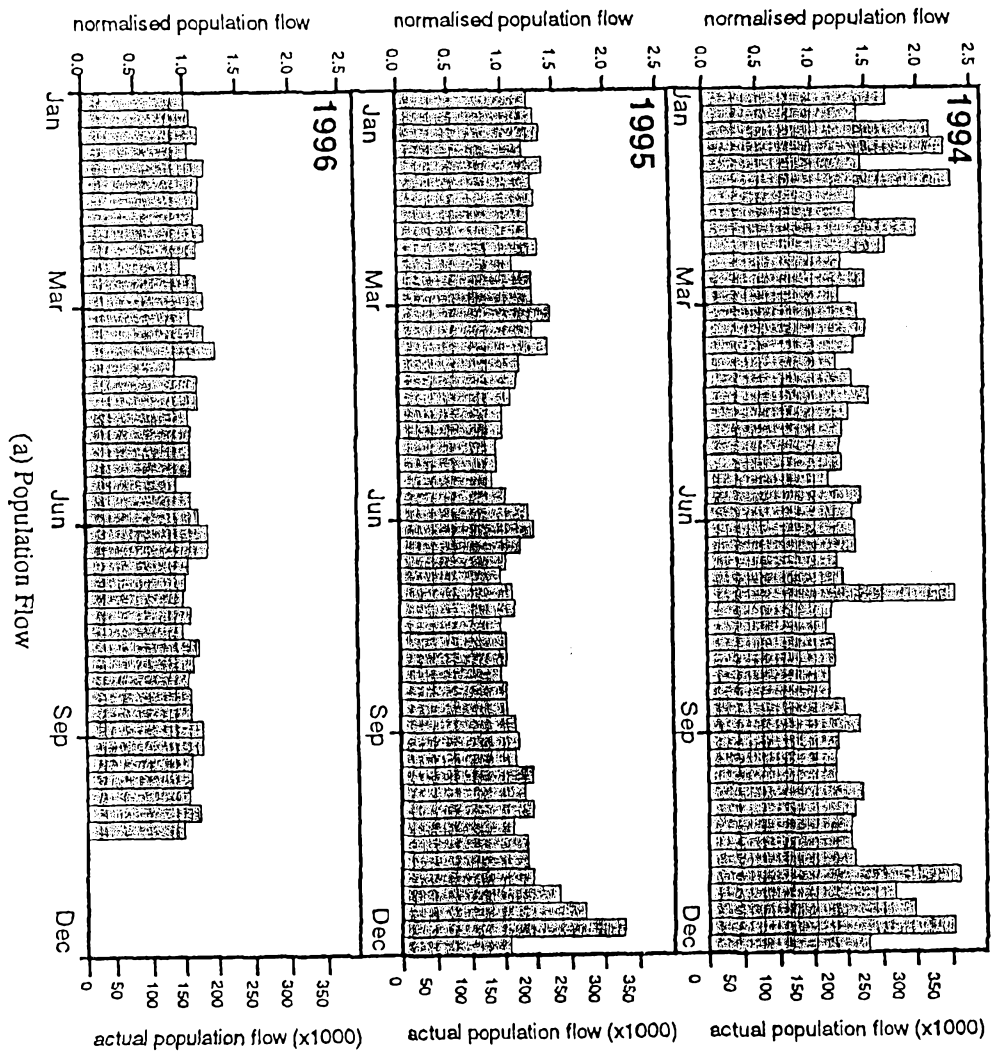
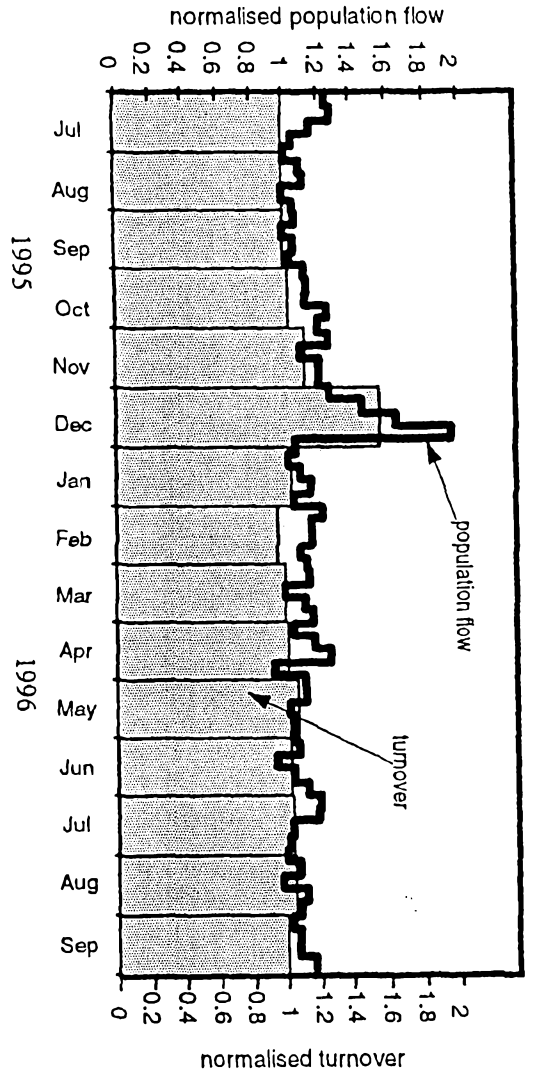

FIGURE 5.1 PROPORTION OF TOTAL SHOP FLOOR AREA OCCUPIED BY SHOPS OF EACH CATEGORY



(a) Population Flow



(b) Comparison of Population Flow and Total Turnover

FIGURE 5.2
BY
AND TOTAL TURNOVER
SHOPPING CENTRE

5.3 GENERAL OBSERVATIONS ON SHOPPING CENTRES

5.3.1 CHARACTERISTICS OF THE CENTRES

The shopping centres studied were from 2 to 5 storeys in height and incorporated major stores, specialty shops and associated uses such as cinemas. Most of the shopping centres surveyed had around 200 specialty shops, though the smallest had only 152 and the largest 370. Each had between 5 and 8 major stores though the largest had 10. Each major store was in excess of 1000m² in area. The shopping centre studied in detail had 43% of its sales floor area given over to specialty shops with 57% being occupied by major stores. This ratio was confirmed by a study of BOMA [10,11] data as being typical for Australian shopping centres.

For each of the centres, interviews were conducted with management staff to understand their approach to various matters relating to fire incidents and evacuation strategies, construction and refurbishment practices and maintenance of fire safety systems. A detailed summary of the findings is given in Appendix F of [6].

5.3.2 FIRE INCIDENTS

It was found that records of fire incidents are not kept and details of incidents must rely on memory. Fires are not uncommon but are almost invariably small, involving cooking fires, fires in rubbish bins, and small electrical fires. Such fires are usually extinguished by the occupants-

5.3.3 CONSTRUCTION AND REFURBISHMENT

As noted above and in [6], walls are only full height between specialty shops or between specialty shops and major stores, if there are security issues such as with banks or jewellery stores. Walls between specialty shops rarely extend to the floor slab above-it being easier to run services within the ceiling space. The void as a result serves a large number of shops. In some specialty shops the ceiling in the reserve area is removed to allow additional storage space, and it has even been observed that some shops extend storage onto the ceilings of adjoining shops. Similarly, it is rare that a fire wall is provided between reserve and public areas in major stores. As noted above, the BCA has no requirements for these situations, unless in the case of the latter, the reserve area is classed as a warehouse. The significance of this practice of discontinuing walls at the ceiling level with respect to potential fire spread needs to be considered and alternatives possibly suggested.

Walls between major stores, and between major stores and specialty shops are full height extending up the floor slab above. This is not a BCA requirement but reflects the desire for store security. Many of the older centres have fire shutters scattered throughout the centre, which close automatically on activation of a smoke detector. The shutters appear to have been provided for a number of reasons:

- to provide compartmentation between a major store and a mall
- fire separation of different classes of buildings

- to restrict compartment sizes in accordance with C2.2 of the BCA
- to restrict compartment sizes to limit fire hydrant requirements
- to restrict compartment sizes which determine smoke control requirements

Numerous accounts of the problems and costs associated with these shutters were received as a result of them closing due to false detector operation. Reinstatement of the shutter was seen to be time-consuming and expensive, and to result in a loss of business for the affected stores. Moreover, the closing of shutters is reported to have resulted in near-casualties, with people almost being trapped under the shutter as it descends, or with damage to the shutter itself due to items of hardware being placed unintentionally below them.

The lease agreements for specialty shops in many shopping centres are renegotiated every 5 years with a significant number of lessees changing at this time. **Modification** of the shop will almost inevitably occur, with changes to the ceiling being significant in the context of this report because of shutdown of the sprinkler system, to be discussed later. Complete shopping centres are typically refurbished every 5 years, with department stores being upgraded about every 10 years.

5.3.4 MAINTENANCE ISSUES

Apart from the issue of fire shutters, outlined above, a number of key issues were raised by centre management in relation to the maintenance of fire-safety systems. Damage and repair of fire doors was seen as a major cost in most centres. Such damage results from impact by goods trolleys as fire-isolated passageways, or parts of these, are often used for the supply of provisions into and out of the centre.

Other issues raised by management were in relation to the provision and maintenance of fire hoses and extinguishers. One centre, which provided extinguishers in public areas, has found that large numbers of extinguishers are stolen each year. Other centres require the lessees or major store owners to provide and maintain extinguishers.

The provision of fire hoses with hydrants is seen by many as unnecessary as it is noted that they are often damaged or stolen. In addition, it appears that the fire brigade will always supply their own hoses due to concern about reliability.

The cost of maintaining a complex smoke control system was also raised as an issue by one operator.

Vandalisation of WIP phones and malicious operation of break-glass points were also noted as giving rise to considerable costs in **some** centres.

5.3.5 SPRINKLER SYSTEMS

As a general rule, shopping centre management has the perception that sprinklers are provided primarily for property protection or insurance purposes, not for life safety. This perception possibly comes from insurance companies who attempt to exercise some control over sprinkler isolation in these buildings.

The management of sprinklers is an important issue in the context of the present study and this is done in various ways. Isolation of a sprinkler system is necessary whenever modifications are required to a ceiling or when a wall must be shifted. It is also required, at some stage, when a major upgrade is being undertaken. If such isolations are not managed properly then the building, *or* part of the building, will be without sprinkler protection for some period of time. For the larger shopping centres, it appears that written approval must be sought from management (with a copy to the insurance company) before isolation of a system is undertaken. The anticipated time of isolation and the duration must also be stated. The time that the system is re-instated must be entered on the form and it is signed off after the system is re-instated. However, in some centres, this practice is not always followed. Also, in many centres, the management of sprinklers for the major department stores may be the responsibility of the store itself. If this is the case, then in some centres, centre management will be notified of any isolations. In other centres, there may be little or no communication on this matter.

Sprinkler isolation always requires notification of the fire brigade with a statement as to when the system will be re-instated.

Information on the frequency and duration of sprinkler isolations has been obtained for three large centres. The records for each centre *cover* a time period of up to two years and are recorded in [6] (detailed in Appendix C and summarised in Figures 4.1 to 4.3). During this period of time there were no major modifications to any of these buildings. For two of the centres, drawings were obtained showing the relationship of sprinkler zones to shops. In the other case, this information was not available.

The total number of sprinkler zone isolations as a function of the time of the year for each of the centres has been analysed. It was noted that the number of isolations around December (when the population is highest) appears to be lower than at other times of the year. *Some* sprinkler zones are found to be common to both major stores and specialty shops where a sprinkler zone covers more than one level and the major store occupies only one level with specialty shops on the others. It was noted that in two of the centres the sprinklers are really only isolated during hours of occupation of the centre. This correlates well with the known fact that insurance companies generally insist that isolations should only occur when the building is occupied.

In addition to the above detailed information, centre managements were asked to comment on the frequency and duration of sprinkler isolations. Responses are summarised in Appendix F of [6]. It was suggested by one manager, that as an average figure, 10% of specialty shops per year require sprinkler isolation for up to one day and that the frequency of isolations for major stores is very much lower-although this appears to be at variance with the above detailed information. As far as major modifications to the building requiring isolation of the sprinklers, it was stated that sprinklers to the occupied areas adjacent to the new construction could be maintained during this process by:

- ensuring that the new construction has a separate sprinkler system if it is large enough, or

- constructing the sprinkler **pipework** in the new part of the building and then connecting the new system to the old in a single day

It appears that for some buildings the above approaches have not always been used.

The implications of the above data for sprinkler reliability must be carefully considered in the light of the activities being undertaken during the periods of isolation. It is important not to draw premature conclusions. The above data are being analysed and the results will be presented in a future report

5.3.6 **EVACUATION**

Most centres have a plan of action on notification of a fire. Many have a fire warden scheme where the fire is investigated by an individual (frequently the chief warden or designate) who will then take responsibility for evacuation. Chief wardens are always associated with centre management although other wardens are chosen from the tenants within the shopping centre-usually the longer term tenants associated **with** the larger stores.

Some fire wardens are of the view that the public would not wish to use fire isolated tunnels in the event of an emergency, since they cannot tell where they lead, but would in preference select a major entrance. Some fire wardens would not wish to guide the public along these routes for much the same reasons.

Fire drills are held in some centres yearly, but are advertised in advance and are conducted when the centre is quiet.

5.3.7 **COMBUSTIBLES WITHIN THE MALL**

It is common for retail areas to be located within the mall. These can arise as a result of show materials being placed outside shops, kiosks being used on a permanent basis within the mall, and exhibitions and temporary shows taking place within the open spaces. In addition, there may be food courts in mall or atrium spaces. Due to their temporary and mobile nature these areas are often not protected **with** sprinkler systems or are too far below sprinklered roofs for the sprinklers to be effective.

5.4 **CONCLUDING REMARKS**

The comments outlined above arise from the interviews with shopping centre management and from the review team themselves. They have been included as part of the list of questions which must be addressed by the project and summarised in Appendix A.

6. OPPORTUNITIES FOR CHANGE

6.1 INTEGRATION OF FIRE SAFETY SYSTEMS

Traditionally, fire safety measures in buildings have been dealt with independently within the design team by the different disciplines involved: architects would design means of escape and positioning of exits; ventilation engineers would design smoke control systems; electrical engineers detection systems and structural engineers fire protection of structure. Each of the different aspects of the total fire safety package could in principle be designed in isolation, and often this was the case. With the introduction of fire safety engineering concepts into design, it has become widely recognised that an understanding of the, interaction between fire safety measures in a building is central to an understanding of the safety of the people within it and the protection of property. Fire safety engineering approaches to building design have begun to be adopted world-wide, and are especially suited to large and complex buildings where the inefficiencies introduced by the separated disciplines approach can be reduced by integrated design. It is proposed to adopt such an approach in the present study to develop a new a set of deemed-to-satisfy requirements which are tailored to the particular circumstances for shopping centres.

6.2 USE OF RESULTS OBTAINED TO DATE

The issues identified in the studies described so far in this report are summarised in Appendix A, in the form of a series of questions which need to be answered in the course of this Project. Several very important additional pieces of information have come out of the studies, which may help to provide some of the solutions.

Firstly, the incidence of death and injury in retail premises is extremely low when compared to the risk of death by fire in other premises. The fire incidents have shown that there have been serious incidents from time to time in various parts of the world, but the statistics have made it clear that these tragedies are not common, and can in many cases be attributed to combinations of adverse circumstances. The very positive results emerging from the analysis of the fire statistics can give confidence that the fire safety levels achieved in retail premises are high.

The BCA review has highlighted areas where the adoption of an alternative approach to fire safety in shopping centres would be beneficial, and has helped to focus the direction of Project 6 activity. The questions posed by the review have been reinforced and extended by the results of the interviews held with shopping centre management. The detailed and general surveys of shopping centres have provided hitherto unavailable information on a number of important issues. The range of fire loads which arises in practice has been established, and will permit probabilistic estimates to be made of the likelihood of the extremes being encountered. Realistic layouts for shops and storage areas have been recorded, so that it will be possible to answer questions related to potential fire growth rates as opposed to fire loads. Actual population figures can be deduced from the flow figures obtained which will remove much speculation in this field. Finally, and most importantly, the frequency of sprinkler isolations has been studied, and the probability of the sprinkler system being unavailable can be estimated.

6.3 SUMMARY OF FUTURE ACTIVITIES

The study is being undertaken in a number of ways:

- position papers
- experimental program
- modelling of fire risk

The number of issues identified in Appendix A is large, and it would be impractical to include all of them in an assessment of fire risk. Where the issues have a significant bearing on one another, such as the design of smoke control systems and the design of means of escape then they are being analysed as part of an integrated risk assessment model. However, where the issues may be identified as largely independent of other systems such as those of fire doors and of WIP phones, these are being addressed by means of position papers which will set out the relevant issues and provide recommendations. These position papers will draw heavily on the results of the shopping centre surveys, as these provide the best record available of what actually takes place in practice as opposed to what might be envisaged by the BCA. These position papers are being currently prepared. All will be published in a future report.

An experimental program is required to answer some fundamental questions about design fires for shopping centres, and the effectiveness of sprinkler protection for input to the fire risk model. The program will be described briefly in this report and more extensively together with results and measurements in a future report-

The modelling of fire risk will be described conceptually here, and as the ideas are developed will be addressed more fully in a future report.

7. SUPPORTING EXPERIMENTAL PROGRAM

7.2 PURPOSE

One of the debates which arises on the fire safety design of shopping centres is the design fire sizes which should be adopted to calculate the requirements for smoke control systems. There is very scant experimental evidence and controversy exists as to how the effects of sprinkler systems should be taken into account. Accordingly an experimental program has been devised as part of this Project.

7.3 SETUP

The experiments are being carried out in a full scale test rig, which represents a shop located in a mall. The fires are located in the shop, which is laid out to represent a typical retail area. Three types of fire load have been selected for study, chosen to represent reasonable worst cases for rapid fire development. These are a retail area in a toy shop, a storage area in a shoe shop and a clothes shop. The shop space in the experimental layout has an area of 10m x 10m and a height of 5m. The soffit is composed of heavy cement sheeting with additional insulation and is laid on bare steel beams supported by unprotected steel columns and carries a sprinkler system laid out in accordance with AS 2118. In the sprinklered tests the sprinkler system was arranged so that is in the most disadvantageous position with respect to the shelving system, so that the water spray does not directly impinge on the burning material and extinguish the fire at an early stage. The opening from the retail area is dependent on the rig layout. The rig is located in a large containing building 50m x 90m x 9m high to the top of the pitched roof. The fire loads selected for the fires represent realistic layouts of the types described, making use of actual combustible material likely to be found in the retail areas under study.

It should be emphasised very clearly that the test arrangements set up represent the worst cases which can be envisaged for the types of shopping centre under study. In no sense can the experimental fires be regarded as typical for the occupancy. The care which has been taken in selecting the shop simulations both in terms of fire load and layout and in arranging for the sprinkler system to be in the most disadvantageous position are there to ensure that the most serious angles have been addressed. There is no evidence in this survey which indicates that these fires could be regarded as likely to occur, but rather that they represent extremes which must be borne in mind when addressing design issues.

7.4 MEASUREMENTS

The experimental program compares sprinklered and unsprinklered fires in each layout. The fire severity is assessed by mounting the material to be burnt on load cells, which measure mass loss. These measurements are only be relevant in sprinklered fires up to the point where the sprinklers operate, at which time the water delivered from the sprinkler head on the load platform interferes with fuel mass loss measurements. However, it is theoretically possible to study fire growth rates, and to estimate the heat release rate when the sprinkler operates. In the unsprinklered case it is possible to investigate fire development throughout the

fire growth period. The fires are terminated when it is judged that it is past its peak or in the unlikely event that there is a threat to the containing building.

Air and structure temperatures are also being measured by more than one hundred thermocouples and radiation levels at various positions.

Smoke production rates are not be measured directly, but video records and direct observations are being used to study smoke layer height. Temperature and smoke obscuration measurements are being taken within the smoke layer. The containing building is nominally sealed against egress of smoke: the smoke filling rate can therefore be compared with that which would have been predicted using conventional calculation methods, and the impact of similar fires in a shopping mall estimated.

8. PROPOSED METHODOLOGY FOR MODELLING OF FIRE RISK

8.1 PHILOSOPHY

In order to try to improve the fire safety measures for shopping centres to make them better fit the building use and increase cost-effectiveness, it is necessary to establish firstly a rational basis which will justify changes, and secondly to develop a method which will demonstrate that fire safety has not been compromised by the change. Accordingly a model is being set up which describes in a time-dependent manner the evacuation of a shopping centre and incorporates the effects on the evacuation process of the fire safety measures which are required by the BCA. In parallel the model will predict the fire growth and smoke spread characteristics associated with the range of design fires (each of which has a probability of occurrence) and the effect of these fires on the building structure. This fire development part of the model will include the effects of installed systems such as sprinklers and smoke extraction. The model will rely on deterministic calculations to estimate parameters such as fire growth and the time it takes people to move to exits and leave the building. But it will also have to allow for the probabilities that, for example, active fire protection systems are inoperative, or that fire protection barriers have been breached. The outcome of a single run of the model would be an expected number of deaths (END) for the particular scenario posed. The challenge of the Project is to pose changes which will not increase the END whilst improving the commercial and functional operation of the centre.

8.2 PARAMETERS FOR STUDY

It would be too large a task to discuss all possible variations of fire safety provisions within a shopping *centre* and the combinations of them. So attention must be focused on those matters which are likely to yield greatest benefits. The foregoing sections of this report have highlighted a number of matters which have come out of the various studies undertaken, and which provide pointers as to the most productive directions for study. The shopping centre managers have expressed their views on the fire safety measures which make shopping centres difficult or expensive to run: the BCA study has shown areas where the current requirements seem to be excessive, especially when considered in the light of the statistical evidence, and the incident reports. It is proposed therefore that a set of measures is selected for particular study and that the fire safety model is run by varying each of these in turn to establish the effect on the END. The measures will then be considered in pairs and variations in the provisions considered, one deemed to have a negative effect and the other a positive. The pairs of measures investigated will be informed by the outcomes of the various studies. On that basis, the following are currently considered to be worthy of further analysis:

- management role
- detection systems
- sprinkler systems
- smoke control systems
- warning systems

- evacuation routes
- exit widths
- structural protection

As an example, an improved sprinkler system might be coupled with longer escape distances and the outcome on END analysed, and so on.

8.3 FIRE SAFETY MODEL

8.3.1 TYPICAL LAYOUTS

Clearly shopping centres can take on an enormous range of layouts, dependant on the size and shape of the centre and local conditions. For the purposes of the study it is necessary to develop typical layouts which will represent all the main features of the centres without being overly complicated. They must be representative and must give adequate recognition to smoke control and evacuation issues. Four design layouts have been chosen such that a typical layout for a single *floor* can be overlaid to form a multi-storey building up to 4 levels above ground plus a basement level. A cinema is to be located at the topmost level. The shopping mall is to be from 1 to 4 storeys, and will include car parking, department stores, and a multi-level department store. One of the selected layouts is shown in Figure 8.1.

8.3.2 EVACUATION MODELLING

The number of people expected to be in a centre at a busy time can be deduced from the surveys undertaken. The evacuation modelling will be assisted using the model EVACSIM [12]. A number of features particular to shopping centres will be included in the model. In particular the model will take careful account of the role of the shopping centre management. In order to do this adequately, a questionnaire has been developed and used in conjunction with shopping centre staff and the results have provided a basis for understanding the manner in which staff would guide people in an evacuation. Such experiences are not unknown and many of the staff will know what actually happens in practice.

8.3.3 FIRE DEVELOPMENT MODELLING

The fire load surveys have indicated which shop categories have the greatest quantities of combustible material, and are therefore likely to give rise to the most serious fires. As noted above it is the storage areas of shoe shops, and the public areas of large toy shops which potentially have the largest amounts of highly combustible material, stacked in such a way as to be likely to give rise to very rapid fire development. It is possible, in principle, to estimate the heat releases rate as a function of time from such a shop fire, but it has been decided that this should be supplemented by a full scale fire tests using realistic fire loads. This fire test program, described in the previous section, is also examining the effects of sprinklers, and alternative sprinkler designs will be considered for effect on the fire growth and suppression rate.

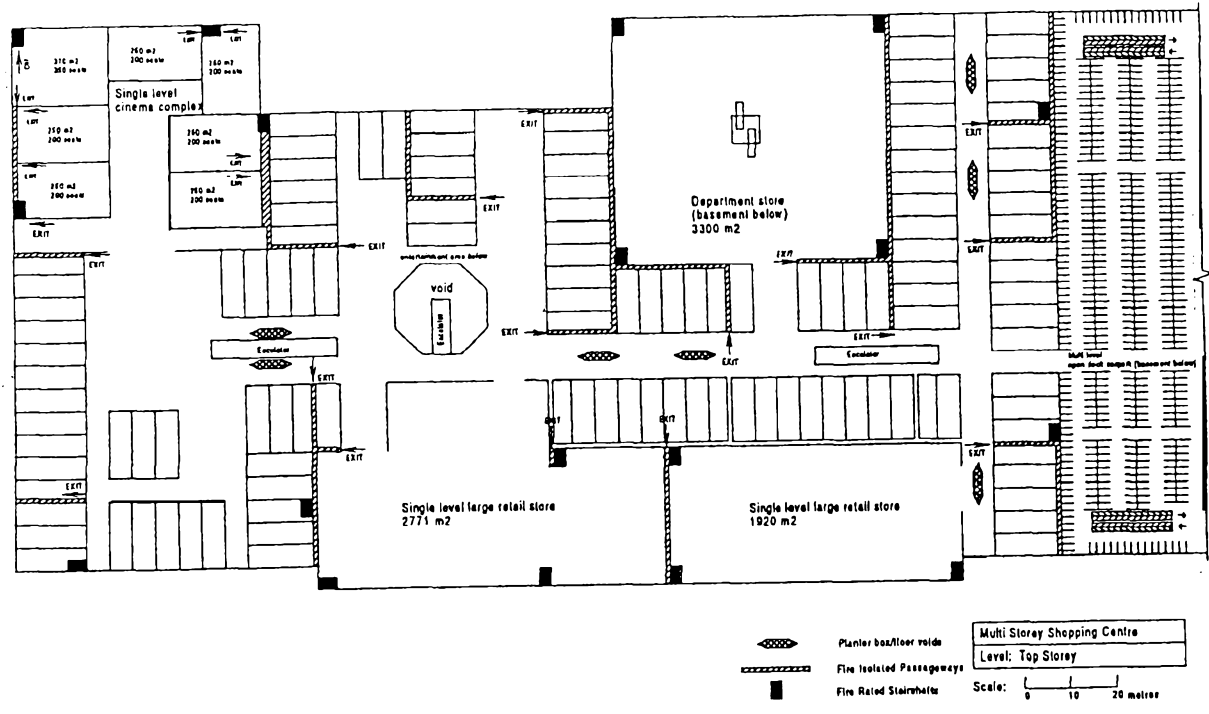
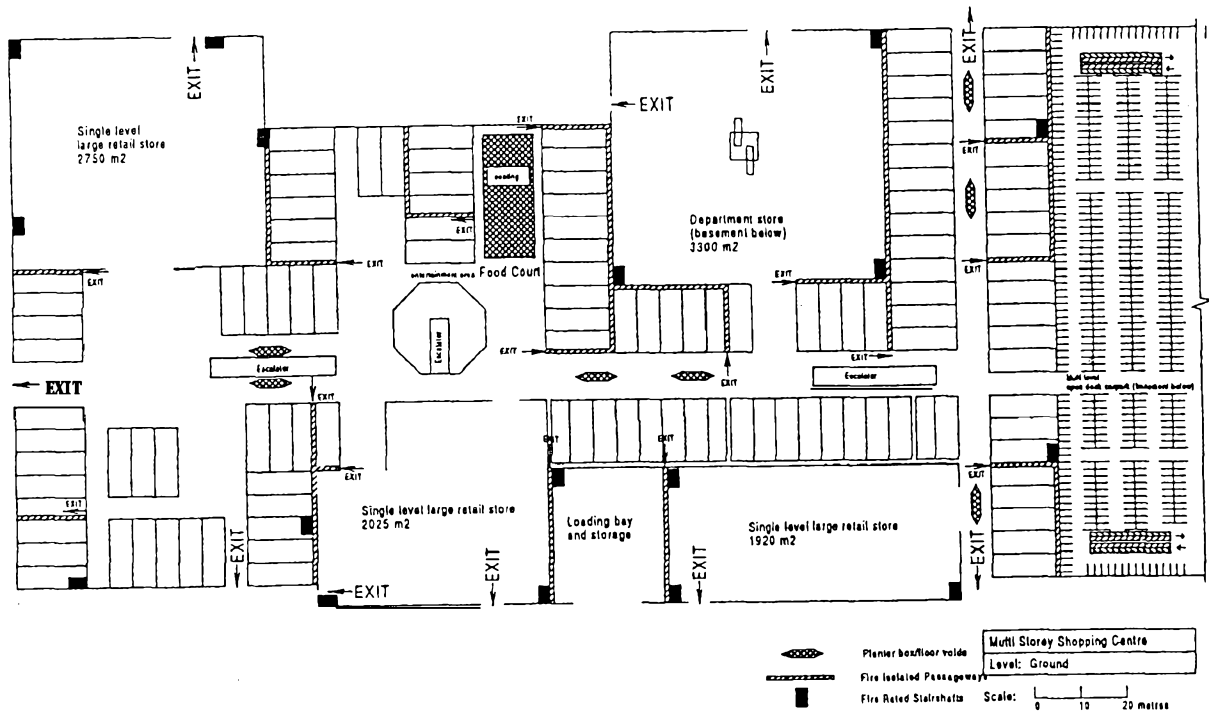

FIGURE 8.1 GENERALISED LAYOUT FOR A DOUBLE STOREY SHOPPING CENTRE, TO BE USED FOR RISK ASSESSMENT MODELLING

8.3.4 **FIRE** BRIGADE INTERVENTION

Advice is being sought from the fire brigade on the provisions which are needed to attempt to mount effective fire fighting operations in a shopping centre. The involvement of the fire brigade as part of the fire-safety system is being considered and the time for intervention will be included as part of the fire safety model.

9. CONCLUSIONS

A series of studies have been carried out in relation to fire safety in low-rise sprinklered shopping centres. These have served to clarify the areas where there could be benefits in reviewing shopping centre requirements. These have been pulled out as a series of questions which have to be addressed by Project 6 and which are given in Appendix A of this report.

The most important points to emerge are as follows:

- current levels of fire safety achieved in shopping centres are very high
- the risk of large fires which would threaten lives is greatest at night when the shopping centre is unoccupied
- the greatest protection to life is to keep the fire small, and detectors, sprinklers and fire fighter intervention all have an important role to play
- many of the fire safety requirements for shopping centre do not appear to have any rational basis
- the fire safety benefit from some requirements is difficult to identify
- many provisions cause financial and operational burdens on shopping centre developers and management

As a result of the questions identified, a methodology has been developed to assess what changes could be made to shopping centre design without affecting the high safety levels currently achieved. Current work involves an experimental program, coupled with further surveys of evacuation management. The modelling exercise is being supplemented with the results from an extensive experimental program, as well as the preparation of a series of position papers on specific issues.

The outcome will be a rational approach which can be used to propose changes to requirements which can be developed and amended as time progresses.

10. SIGNATURE PAGE

Report written by:

Approved by:



P F Beaver
Associate Professor
(Victoria University of Technology)



K R Slattexy
Manager Research-Steel Market Programs

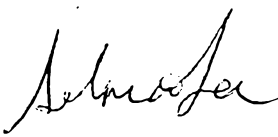

A C Lee
Liaison Officer
(Building Control Commission)

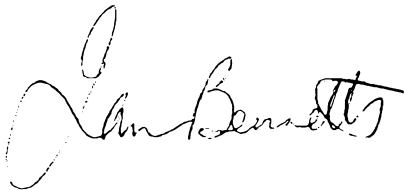

I D Bennetts
Research Associate



K W Poh
Senior Research Engineer



S L Poon
Senior Research Engineer

11. REFERENCES

1. Bennetts, I. D., Poh, K. W. and Lee, A. C., "BCA Fire Safety Requirements for Shopping Centres", (Fire Code Reform Centre Project 6), BHP Research Report No. BHPR/SM/R/045, June 1996.
2. Bennetts, I. D., Poh, K. W., Thomas, I. R., Lee, A. C., and Beever, P. F., "Case Studies of Fires in Retail Buildings", (Fire Code Reform Centre Project 6), BHP Research Report No. BHPR/SM/R/056, October 1996.
3. Thomas, I. R., "Analysis of US Retail Fires", (Fire Code Reform Centre Project 6), BHP Research Report No. BHPR/SM/R/G/056, February 1997.
4. Thomas, I. R., "Analysis of Fires in Australian Commercial Buildings", (Fire Code Reform Centre Project 6), BHP Research Report-in preparation.
5. Thomas, I. R., "Analysis of NSW Retail Fires", (Fire Code Reform Centre Project 6), BHP Research Report-in preparation.
6. Bennetts, I. D., Culton, M., Dickerson, M., Lewins, R. R., Poh, K. W., Poon, S. L., Ralph, R., Lee, A. C., and Beever, P. F., "Shopping Centre Review", (Fire Code Reform Centre Project 6), BHP Research Report No. BHPR/SM/R//G/058, January 1997.
7. "National Fire Incident Reporting System", Federal Emergency Management Agency, USA.
8. Favre, J. P., "Design of Buildings for Fire Safety in Switzerland", Design of Steel Buildings for Fire Safety-European and Australian Perspective, Seminar Proceedings, 1996.
9. "AS 2118, Automatic Fire Sprinkler Systems (SAA Code for Automatic Fire Sprinkler Systems)", Standards Australia, 1982.
10. Building Owners and Managers Association, (BOMA) Australian Council of Shopping Centres, "Shopping Centre Directory-Victoria 1995/96".
11. Building, Owners and Managers Association, (BOMA) Australian Council of Shopping Centres, "Shopping Centre Directory-NSW/ACT 1995".
12. Poon, S. L., "EvacSim: A Simulation Model of Occupants with Behavioural Attributes in Emergency Evacuation of High-Rise Building Fires", Proceeding of the Fourth International Symposium on Fire Safety Science, 1994.

APPENDIX A
QUESTIONS EMERGING FROM THE STUDIES
TO BE ADDRESSED BY PROJECT 6

Fire Separation and Compartmentation

- Are the BCA provisions for large isolated buildings appropriate for shopping centres?
- Under what circumstances is it reasonable to require separation between parts of different classification or of different height and what separation requirements, if any, are appropriate?
- What are the consequences of having non-compartmentalised ceiling spaces running over many shops in the centres?
- To what extent do floors need to be fire resisting?
- What fire resistance level is appropriate for fire doors?
- Under what circumstances should mall roofs be fire resisting or sprinklered?
- Why are roof lights restricted to a maximum of 20% of the roof surface?

Fire Resisting Construction

- Is the relationship between type of construction and number of storeys correct?
- What level of fire-resistance is appropriate and what allowance should be made for the presence of sprinklers?
- In requiring that structures should be stable in fire conditions is it fair to assume that the structure on floors apart from the fire floor remains intact?

Exits

- What is the basis of these travel distance requirements? Can they be increased for these buildings?
- Are required exit widths appropriate for these buildings?
- Are fire-isolated passages useful?

Smoke Hazard Management

- What is a reasonable basis for designing a smoke hazard management system for shopping centre buildings?
- What fire location should be considered for design?
- What is the effect of sprinklers? How effective will the system be in exhausting the smoke from a sprinklered fire?
- Are the exhaust fan capacities and air flow requirements specified in BCA Spec G3.8, Clause 3.4 appropriate?
- How will the smoke management system in a major store and the one in the mall interact if both were to operate together?
- How reliable are smoke management systems?
- Why is it not acceptable to use heat and smoke vents in an atrium where a Clause 6 part of the building adjoins the atrium, but this would be permitted in a mall?
- When should stair pressurisation be required in these buildings?

Atriums

- In the case of sprinklered shopping centres is it appropriate for the atrium requirements to be applied? What is different compared with a building having a rise in storeys of 3 to which none of the atrium requirements apply?
- What is the basis for the required boundary wall construction for an atrium? Is this justified in sprinklered shopping centres?
- Why are break glass fire alarms required at doors to fire-isolated exits and are they an effective fire safety measure?
- Under what circumstances is it necessary for the atrium roof to be sprinklered?
- What is the basis of the atrium standby power requirements? Are they justified for the buildings under consideration?

Sprinklers

- Is it appropriate for these buildings to have a Grade III water supply for the sprinkler system or should they have a Grade I or II supply?
- What is the reliability of sprinkler systems in shopping centres?
- How can sprinkler reliability/performance be improved?
- How can sprinkler isolation be better managed?
- What, if any, sprinkler protection is required for situations where there are combustible materials in the mall?

Communication

- Should all shopping centres over a certain size have EWIS systems?
- Are WIP phones and manual call points useful, or do they represent outmoded technology?
- Are other communication systems such as voice alarms appropriate?
- How can the role of centre management in communicating to the public be accounted for?

Fire-fighting

- Are hand-held fire extinguishers useful?
- Where should hydrants be located and what water supply is required for these buildings?
- Are fire hoses needed as well as hydrants?
- Are the requirements for fire service access around the whole building perimeter necessary?